

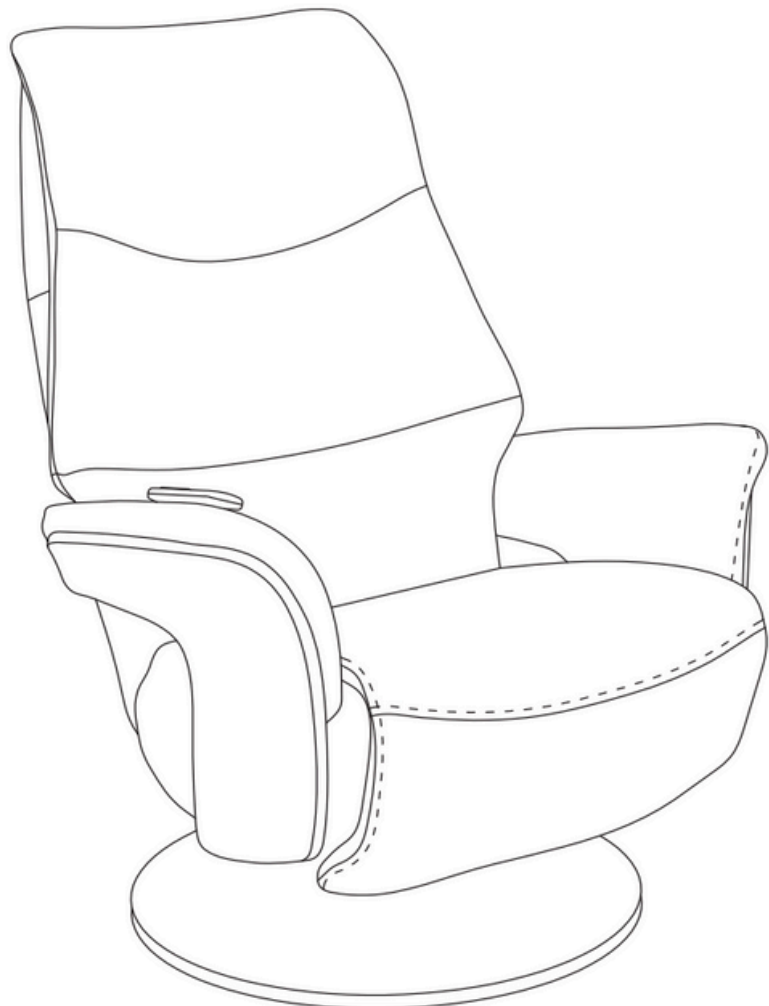

UTAH

Swivel Recliner & Footstool

ASSEMBLY INSTRUCTIONS



STOP! IMPORTANT:

Please read this manual carefully before beginning assembly of this product.
Keep this manual for future reference.
Use the product only in a way specified under instruction manual.
Incorrect usage voids product warranty.

FIRE RETARDANCY

The chairs leathers/bonded leathers/PUs/fabrics meet the requirements of BS5852 Part 1 Source 0 (Cigarette) Ignition Source 1 (Match) as laid out in the UK Furniture and Furnishings (Fire)(Safety) Regulations 1988 with amendments in 1989, 1993 and 2010.



IMPORTANT

This product is designed to seat people up to a maximum of 115kgs (18 stone)

Check and re-tighten parts/nuts & bolts every three months

**Please retain these instructions for future reference and in case of any queries,
please quote the following batch number to your retailer.
(The batch number is also located on the underside of the seat pad or
footstool pad)**



SAFETY INFORMATION

WARNING:

This item contains small parts which can be swallowed by children and pets. Keep children and pets away during assembly. To avoid danger of suffocation, always keep plastic bags away from children and pets.

We recommend that you assemble this unit on a carpeted floor to avoid scratches.

We do not recommend the use of power tools for assembly as this could damage the unit. Only use manual tools.

CARE INSTRUCTIONS

Wipe regularly with clean water and a damp, clean, soft white cloth

General cleaning can be done as needed with a mild detergent and water solution. Always rinse with clean water and dry

For heavy soiling, dampen a soft white cloth or soft bristle brush. Use care as scrubbing can damage the surface

More difficult stains can be treated, but this should be occasional, not daily, cleaning

ANY cleaning solution used must be removed with clean water and a clean white cloth

Cleaning residue left on the material can cause it to dry out and crack, or affect the colour

WARRANTY

Thank you for purchasing a product from Furniture World. These products have been made to demanding, high-quality standards and are guaranteed for domestic use against manufacturing faults for a period of 12 months from the date of purchase. This warranty does not affect your statutory rights. We reserve the right to repair or replace the defective product, at its discretion. This product is guaranteed for 12 months if used for normal purposes. Any warranty is invalid if the product has been overloaded or subject to neglect, improper use or an attempted repair by other than an authorized agent. Heavy-duty or daily professional/ commercial usage are not guaranteed. Due to continuous product improvement, we reserve the right to change the product specifications without prior notice.

PRE ASSEMBLY INSTRUCTIONS

Identify all the parts and hardware.

Do not discard of the packaging until you have checked that you have all of the parts and hardware required.

Hardware package may have spare parts.

What you need



30
MINUTES



2
PEOPLE



0
EXTRA TOOLS

HARDWARE DESCRIPTION

A



Qty1

B

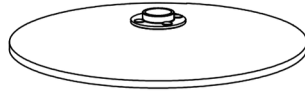

Qty1

C



Qty1

D

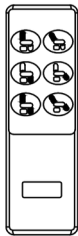

Qty1

E



Qty1

F



Qty1

CHAIR ASSEMBLY

STEP 1

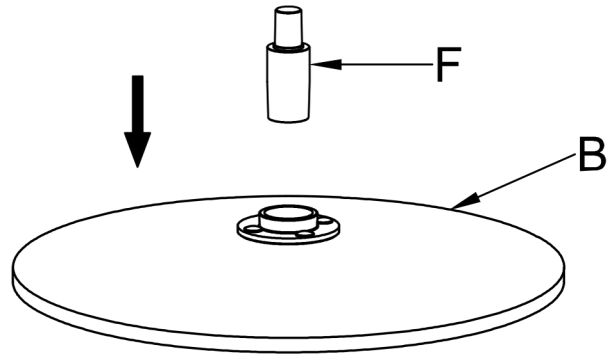

STEP 2

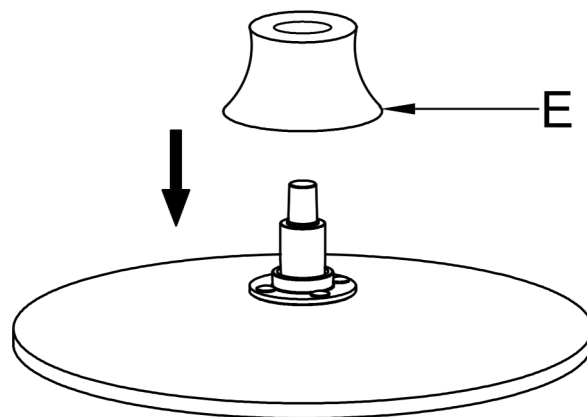

CHAIR ASSEMBLY

STEP 3

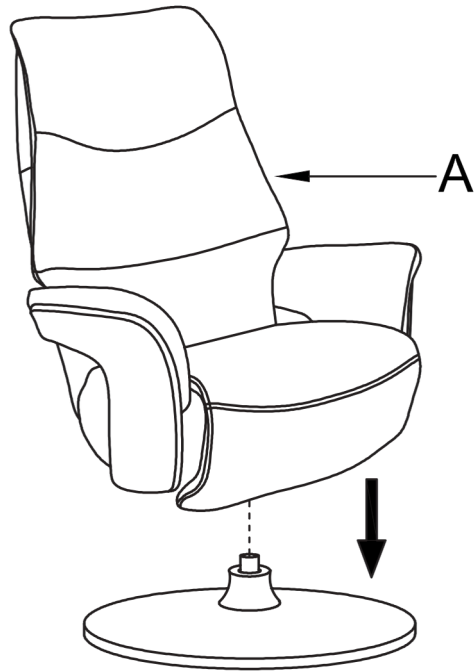

STEP 4

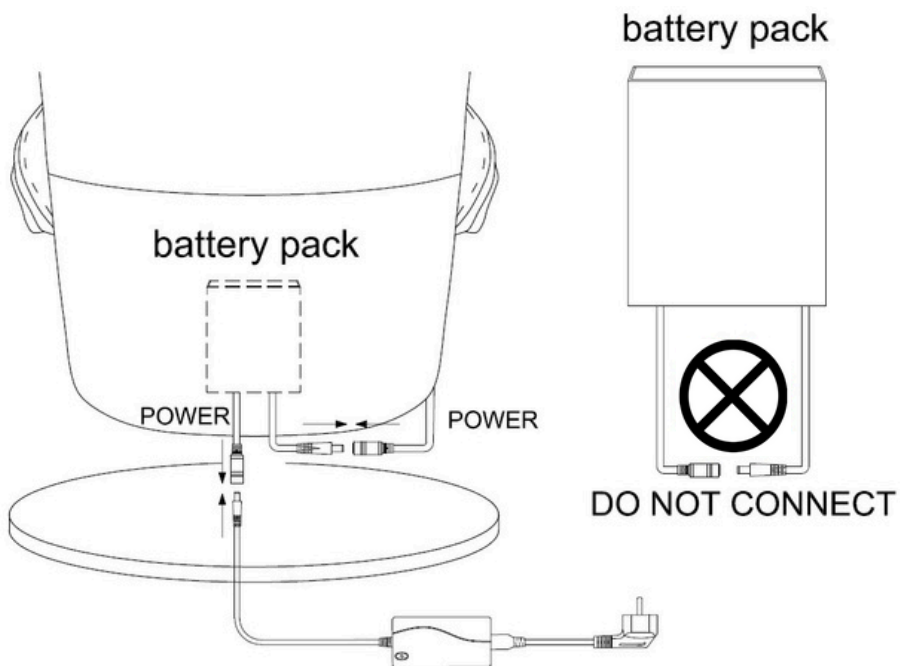

CHAIR ASSEMBLY

STEP 5

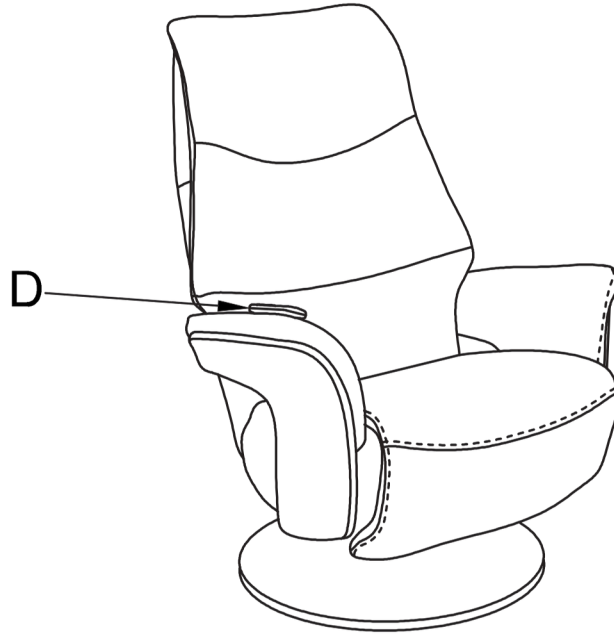

STEP 6

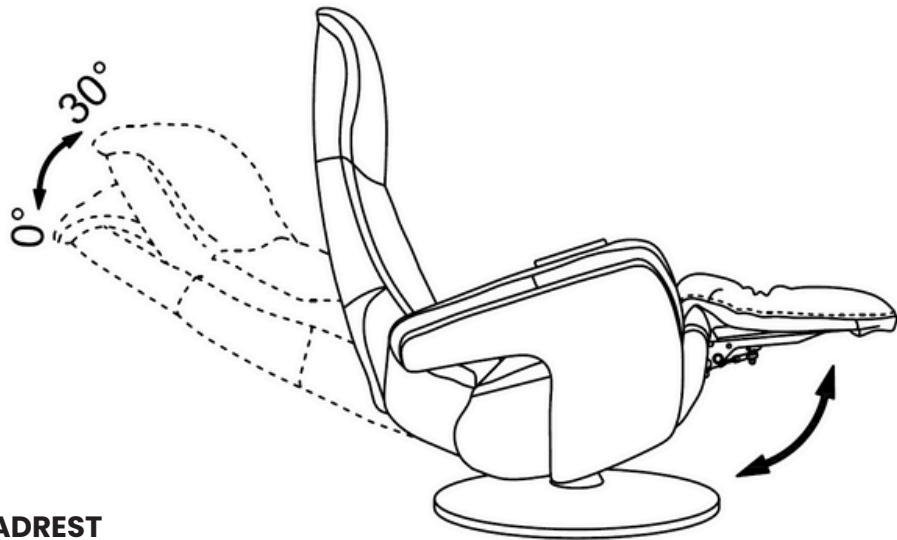

ADJUSTING THE HEADREST

The headrest is not controlled by the handset.
To adjust the headrest grip the backside of of the headrest and pull forward.
To adjust the headrest backwards, push on both sides or use forearm to evenly move the headrest backwards.

BATTERY INSTRUCTIONS

The battery needs to be activated by powering it on when you use it in the first time. After powering it on, there is a 10 second delay time, and then an indicator light will flash to show you can use it. If the battery pack isn't used for a long time, it is recommended to reactivate it by charging. The battery needs to be charged every three months to help maintain a healthy cycle of battery cells. When the battery pack has low charge, a sound will beep as a warning/reminder to charge. It needs 8 hours to fully charge. It is important to ensure the battery is regularly charged and not left flat for too long. **Prevent overcharging** Always unplug the cable when fully charged. This helps prevent overcharging, which may result in overheating, shortening battery life, or even an outburst or fire. Please refer to user instructions for charging instructions to practice proper battery safety. **Avoid temperatures above 45 degrees** This includes keeping the chair and battery near heat sources such as a fireplace, direct sunlight or heaters/radiators. Doing so may result in causing the battery to leak and overheat, which can cause electrical damage and fires. **Do not spill liquid on batteries or live electrical components** Doing so may result in batteries being charged with an abnormal current or voltage. This can cause general overheating, explosions, and fire risks with your battery-powered recliner. **Do not modify any electrical components or batteries** This may result in electrical damage or fire, and the contents may cause chemical burns or other reactions. If you tamper with electrical components or batteries, you will void the warranty on your recliner. **Be aware of odours, overheating, discolouration or unusual reactions during use** In the event of any unusual reactions during use, recharging or storage, immediately disconnect the charger. These hazards may result in overheating, electrical damage, and fires. **If the battery leaks, disconnect the charger immediately** Always ensure it is placed away from any naked flame. The leaking electrolyte may be flammable and can cause the battery to explode or catch fire. Do not use if any leaking is present or you suspect this.